

# POWERFLEX®

PART NUMBER

## 19-2201G

DESCRIPTION

## FRONT ARM FRONT BUSH

### INSTALLATION GUIDE

#### Contents (parts per pack):

- |                             |                              |
|-----------------------------|------------------------------|
| 2 x Polyurethane Bushes     | 1 x PTFE/Silicone Grease     |
| 2 x Stainless Steel Sleeves | 2 x Stainless Steel Adjuster |
| 1 x Spanner 34AF            |                              |

Please read the complete fitting instructions and check package components before fitment. These fitting instructions are to be used as a guide and in conjunction with workshop manual.

It is recommended that:

- all work to be carried out by a licensed technician;
- all safety precautions adhered to;
- wheel alignment to be checked and adjusted as required after any suspension work.
- All fasteners must be tensioned to manufacturer's torque settings.

#### Fitting Instructions:

1. Remove the original bush from the arm.
  2. Clean any dirt or burrs from the bore in the arm. Remove any sharp edges with a rounded file.
- Tip: To aid fitment, apply some washing up liquid to the bore of the arm and body of the bush.**
3. With the chamfered lip of the polyurethane bush facing the rear of the car, press in the bush into the arm
  4. Apply the supplied grease to the bore and the mounting faces of each bush.
  5. Fit the stainless-steel sleeve into the bushes with the machined end facing forwards and then add the machined hex adjuster.
  6. For maximum camber, use the supplied spanner to rotate the sleeve so that the bore is positioned as shown in figure 2.
  7. Refit arm and tension all hardware to manufacturers recommended torque settings

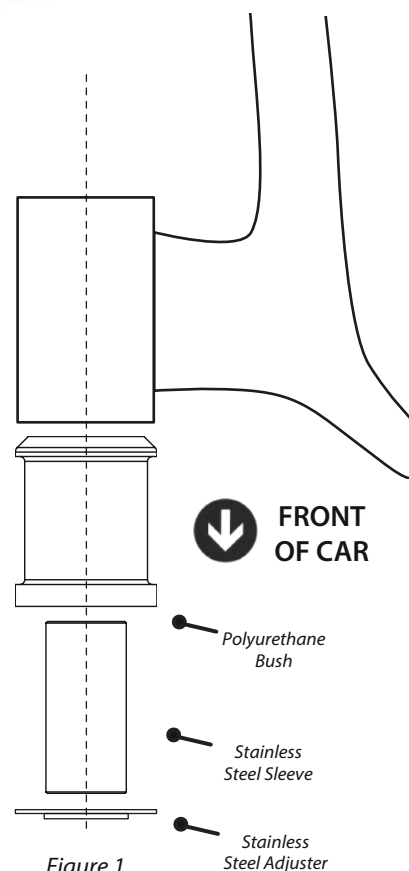

Figure 1  
Offset Hole for Adjustable Camber

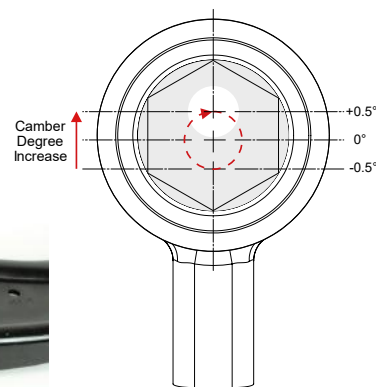

Figure 2

